

ITB# 2401710140001

City of Hendersonville  
Addendum

**ADDENDUM 2**

Date of Addendum: March 10, 2025

Project Name: COH Ops Building Renovation

The attention of all Bidders on the above Contract is called to this Addendum No. 2:

**A. Meeting Minutes**

- a. Meeting minutes and an attendance list from the Prebid Conference held on March 10, 2025, at 11:00 AM are attached to this addendum.

**B. Advertisement For Bid**

- a. Bids will now be opened March 25th, 2025 at 1:00 PM local time.
- b. Delete PDF page 2 from the project manual and replace with the attached Invitation to Bid.

**C. Timeline for Work**

- a. Replace "150 consecutive calendar days" under Time of Construction on PDF page 8 with "180 consecutive calendar days."

**D. Drawing Update**

- a. Delete Sheet A102 from the architectural drawings and replace with the attached Sheet A102.
- b. This incorporates a small hatch update for Office 143

**E. Acknowledgement by bidder**

- a. Each bidder is required to acknowledge receipt of this Addendum No. 2 and previous addenda in the space provided in the Bid Form.

**CITY OF HENDERSONVILLE**



Richard Shook, PE  
Civil Engineer

CITY OF HENDERSONVILLE

City Operations Finishes Renovation

**PREBID CONFERENCE MINUTES**

March 10, 2025

11:00 AM

1. INTRODUCTIONS

- A. Attendance at pre-bid is highly encouraged but is not mandatory. The attendance list will be attached to the minutes of the pre-bid conference.

2. PROJECT DESCRIPTION

- A. Work to be performed under these Contract Documents include the following:
- Renovation of the first floor of the City Operations Building.
- B. Federal Funding Reimbursement

3. INSTRUCTIONS TO BIDDERS

- A. Examination of Site
- Photographic Log
  - Site visits by appointment
- B. Interpretations and Addenda
- All questions regarding the meaning or intent of the Bidding Documents are to be submitted in writing. Email Richard Shook, PE [rshook@hvlnc.gov](mailto:rshook@hvlnc.gov).
  - All changes and noteworthy clarifications will be issued by Addenda.
  - Only questions answered by Addendum will be binding. Oral answers will not be binding.
  - Questions received less than seven days prior to the date of opening of Bids may not be answered.

C. Submittal of Bid

- Each Bid Proposal must be submitted in a sealed envelope to indicate its contents without being opened. Please review the Instructions to Bidders regarding submitting sealed bids.
- The Bidding Forms must be filled out completely
- Bidder may only submit one Bid
- To be included with the Bid:
  - Executed Form of Proposal
  - Bid Bond
  - Contractor's License No.
  - Certification Regarding Lobbying
  - Non-Collusion Affidavit

D. Bidder shall acknowledge receipt of any addenda on the Form of Proposal

E. **March 21, 2025, at 1:00 p.m. local time** at City Hall, 160 6<sup>th</sup> Ave E, Hendersonville, NC 28792 in the second-floor conference room (council room).

• **Changing to March 25<sup>th</sup>, 2025 1:00pm local time.**

- Please arrive early to provide time to find the second-floor conference room
- Use the first floor public entrance, take the elevator to the second floor, then turn right through a hallway to the second-floor conference room.

4. CONTRACT REQUIREMENTS

A. Notice of Award

- Bids shall be subject to acceptance for 60 days after Bid opening.

B. Performance and Payment Bonds

- Shall be submitted within 10 days of Notice of Award.

C. Execution of Agreement

- Contractor shall execute the Agreement within 10 days of Notice of Award.

D. Certificate of Insurance

- Certificates of Insurance shall be submitted within 10 days of Notice of Award.

E. Notice to Proceed

- Notice to Proceed will be issued on the 30<sup>th</sup> day after the Effective Date of the Contract or otherwise issues by the City.

F. Contract Times

- Milestone 1 completion is 90 days from NTP
- Substantial Completion is 180 days from NTP

G. Liquidated Damages

- \$500.00 per day construction is delayed beyond Substantial Completion.
- Liquidated Damages are not additive and will not be imposed concurrently

5. PROJECT REQUIREMENTS

- Base Bid
  - Milestone 1
- Alternate 1 – Space Improvements
- Alternate 2 – Gutter and Downspout Replacement

6. QUESTIONS AND ANSWERS

- **Ray Wallen with Dunlap will email an question about wall fire ratings in the assembly room to Richard.**

City of Hendersonville  
City Operations Renovation  
Prebid Conference 3/10/2025 11:00  
Virtual - Microsoft Teams  
Attendance List

Name	Organization	Title
Richard Shook	City of Hendersonville	Civil Engineer
Chris Conard	City of Hendersonville	Engineering Inspections
Brendan Shanahan	City of Hendersonville	City Engineer
Matthew Byrd	Cooper Construction	
Wilson Bunn	Solid Core Construction	
Jill Wallen	Dunlap Construction	
Ray Wallen	Dunlap Construction	
Matt Wentworth	Enterprises G	
Maxwell Deholl	Modern Mountain Builders	

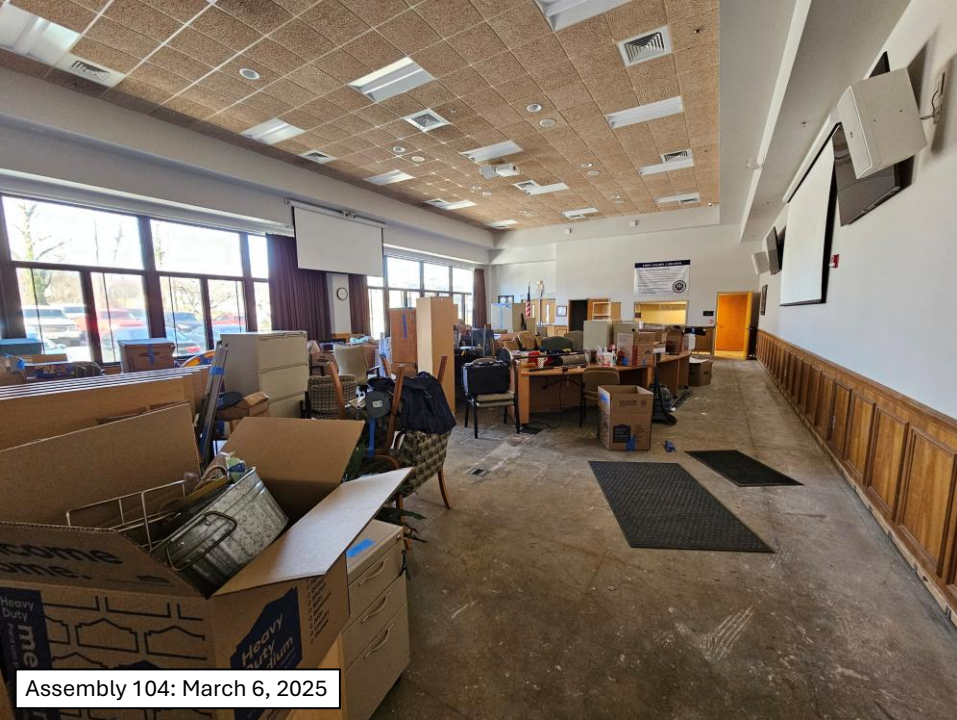

Assembly 104: March 6, 2025



Room 110: March 5, 2025







Corridor 153: March 5, 2025

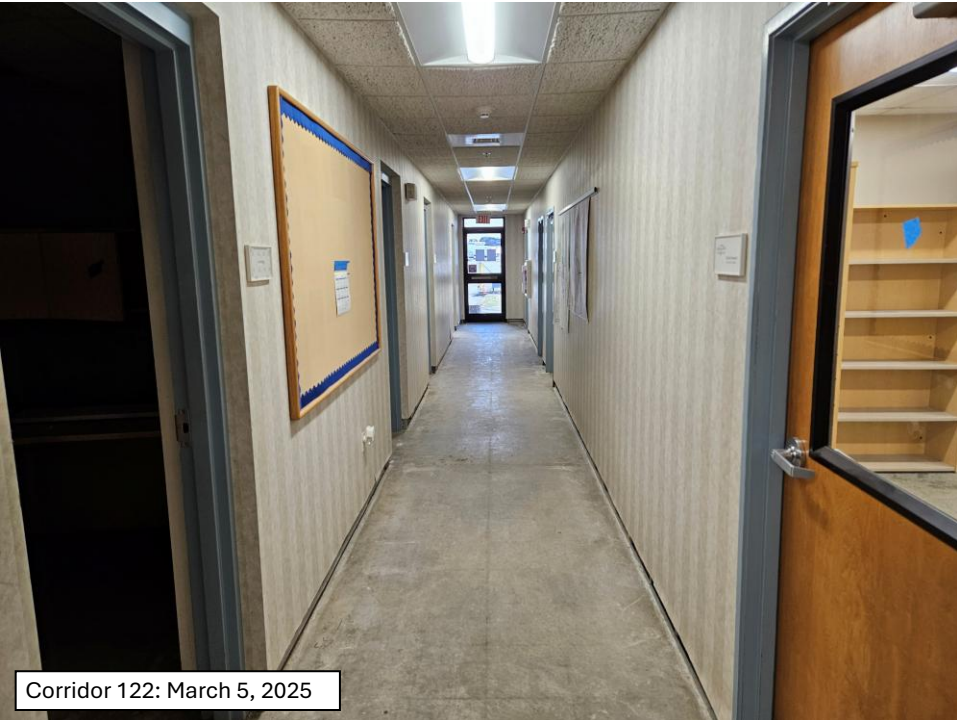

Corridor 122: March 5, 2025





## **INVITATION TO BID #240171014001**

### **FOR THE CONSTRUCTION OF CITY OPERATIONS BUILDING FINISH RENOVATIONS**

**City of Hendersonville, North Carolina**

Sealed, single prime bids for the construction of City Operations Building Finish Renovations at 305 Williams St will be received by the City of Hendersonville at City Hall Second Floor Meeting Room (Council Room), located at 160 6<sup>th</sup> Ave E Hendersonville, NC, 28792 until **1:00 PM, local time, March 25, 2025**, and there at said office, at said time, publicly opened and read aloud. Bids submitted in advance should be sent to 305 Williams Street, Hendersonville, NC 28792 to the attention of Richard Shook. Bid Proposals will be received for

### **CITY OPERATIONS BUILDING FINISH RENOVATIONS City Project Number 24017**

This Project includes, but is not limited to the renovation of the 18,850 SF first floor of the City Operations Center. The Operations Center was flooded during Hurricane Helene and all damaged materials have already been removed. The base bid for this project includes replacement in kind of existing finishes to restore the first floor to conditions prior to Helene. The single bid alternate includes improvements that will enhance the function of the first floor.

Milestone 1 includes work at the public entrance and assembly room to return this area to daily use. This milestone must be completed within 90 days of notice to proceed. This area is shown on the plans as a hatch in detail B1 on Sheet A-102. Please see the rest of the project manual and architectural drawings for more detail.

The Bid Package, consisting of the Invitation to Bid, Instructions to Bidders, Bid Proposal Form, Non-collusion Affidavit, Substitution Listing Form, General Conditions of the Contract, and Contract Drawings are available through the online electronic bid service <http://www.questcdn.com/>. QuestCDN shall be considered the Issuing Office for the purposes of the bid documents. You may download the digital plan documents for a non-refundable charge of \$22.00 by inputting Quest project #**9545634** on the website's Project Search page. Please contact QuestCDN.com at 952-233-1632 or [info@questcdn.com](mailto:info@questcdn.com) for assistance in obtaining a free membership registration and downloading this digital project information. Prospective bidders are responsible for obtaining complete Plans, Specifications, and Bidding Documents, including any Addenda.

Bid bonds, payment bonds and performance bonds will be required for this Project.

Bidding, award, and construction of this project are subject to the requirements of Uniform Administrative Requirements, Cost Principles, and Audit Requirements for federal awards (Uniform Guidance) codified at 2 C.F.R. Part 200

If awarded, the Project will be awarded to the lowest responsive, responsible Bidder, taking into account quality, performance and time specified in the Contract Documents. The lowest, responsive, responsible bid will be determined based upon the lowest cost to the City.





City of Hendersonville



14 O'HENRY AVENUE, SUITE 210 ASHEVILLE, NC 28801 TEL. 828.254.1963 WWW.LS3P.COM

COPYRIGHT 2024 ALL RIGHTS RESERVED. PRINTED OR ELECTRONIC DRAWINGS AND DOCUMENTATION MAY NOT BE REPRODUCED IN ANY FORM WITHOUT THE WRITTEN PERMISSION FROM LS3P ASSOCIATES LTD.

COH-Ops Building Finishes Renovations 305 Williams St Hendersonville, North Carolina 28792 LS3P PROJECT: 0101-240874

Table with columns: #, DATE, DESCRIPTION

SHEET NAME: ALTERNATE - FLOOR PLAN - LEVEL 1

ORIG SUBMISSION: 2025.01.10

SHEET: A-102

ROOM FINISHES - ALTERNATE

Table with columns: NUMBER, NAME, WALL, FINISH, BASE, FLOOR, NOTES

FLOOR PLAN NOTES BY NUMBER

- 1 CLIENT TO CONFIRM FUNCTION OF FLOOR OUTLETS. CONTRACTOR TO MAKE ANY REPAIRS NECESSARY.

LEGEND- ELEVATIONS

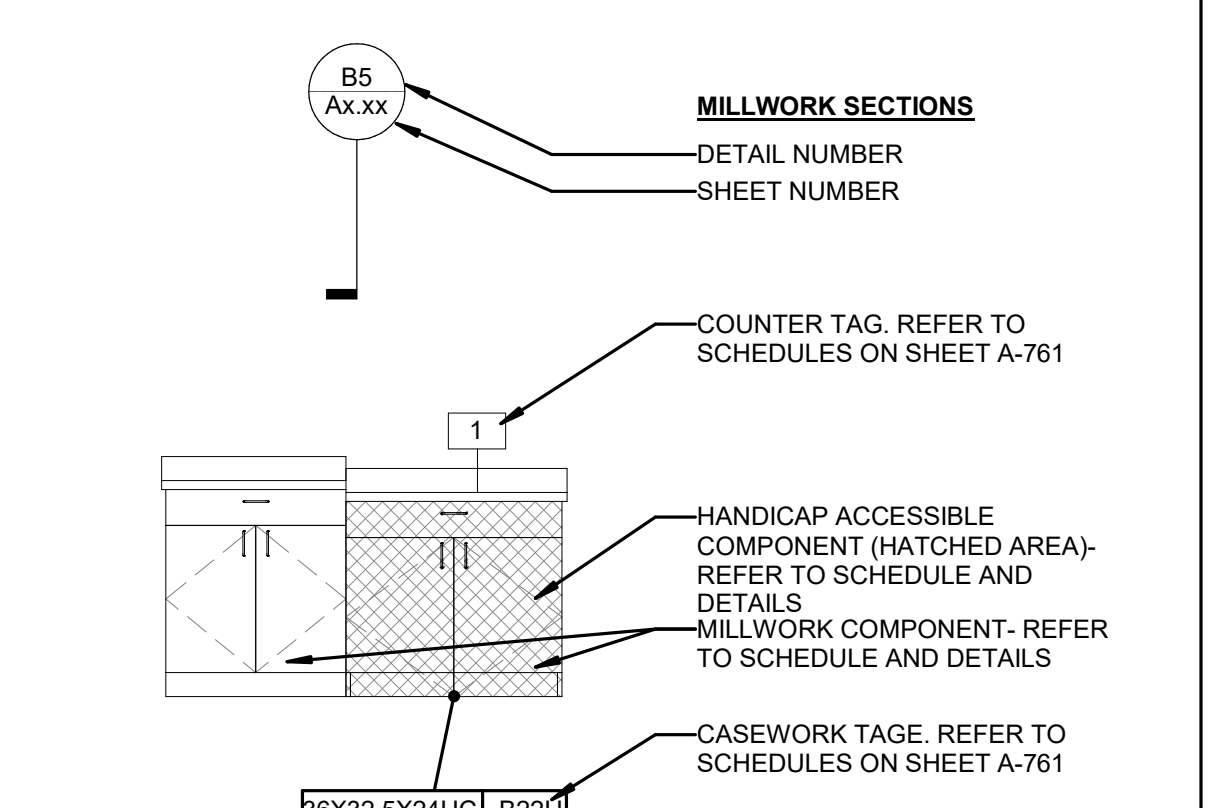

FLOOR PLAN LEGEND

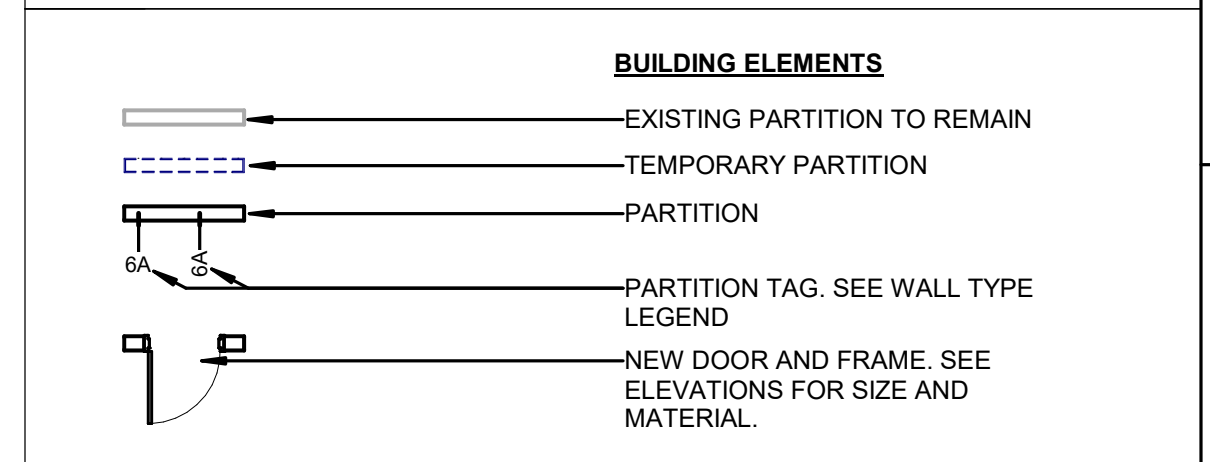

FLOOR PLAN SHEET NOTES

- A. PATCH AND REPAIR ALL DRYWALL MISSING AT BASE OF WALLS.

FLOOR FINISH LEGEND

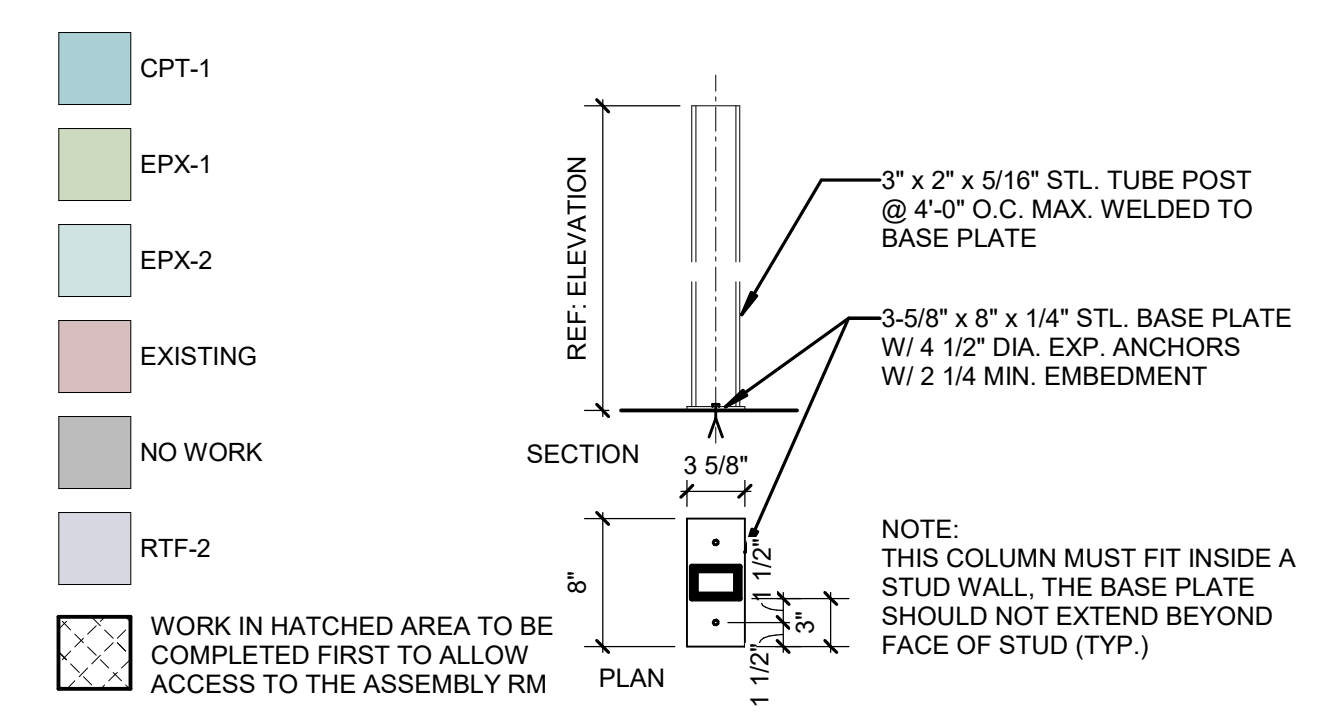

(PARTITION - FREE STANDING SUPPORT)

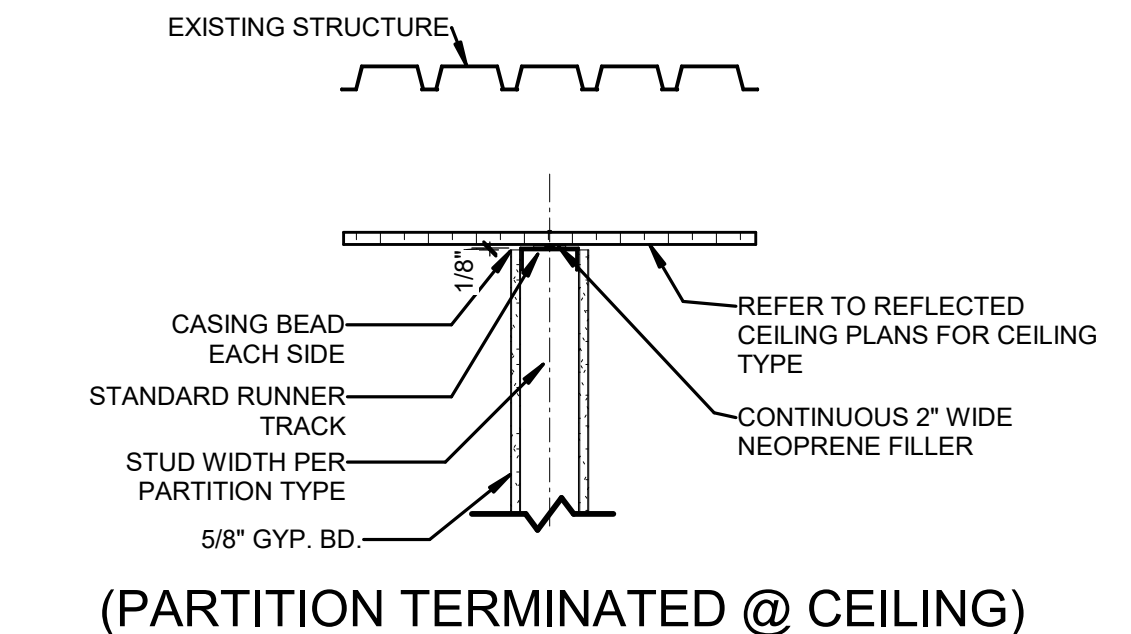

(PARTITION TERMINATED @ CEILING)

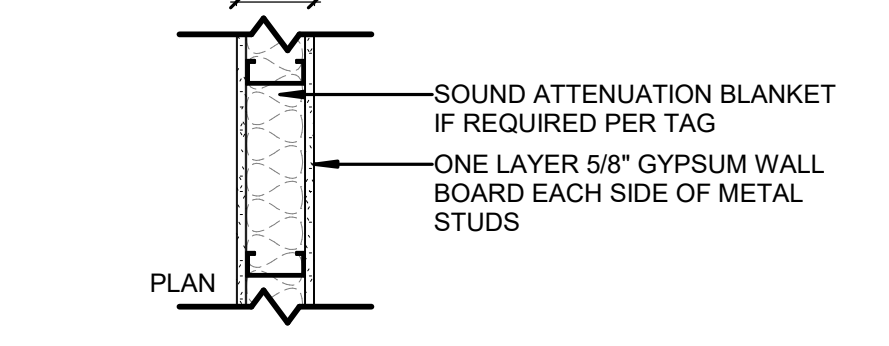

NEW PARTITION DETAILS

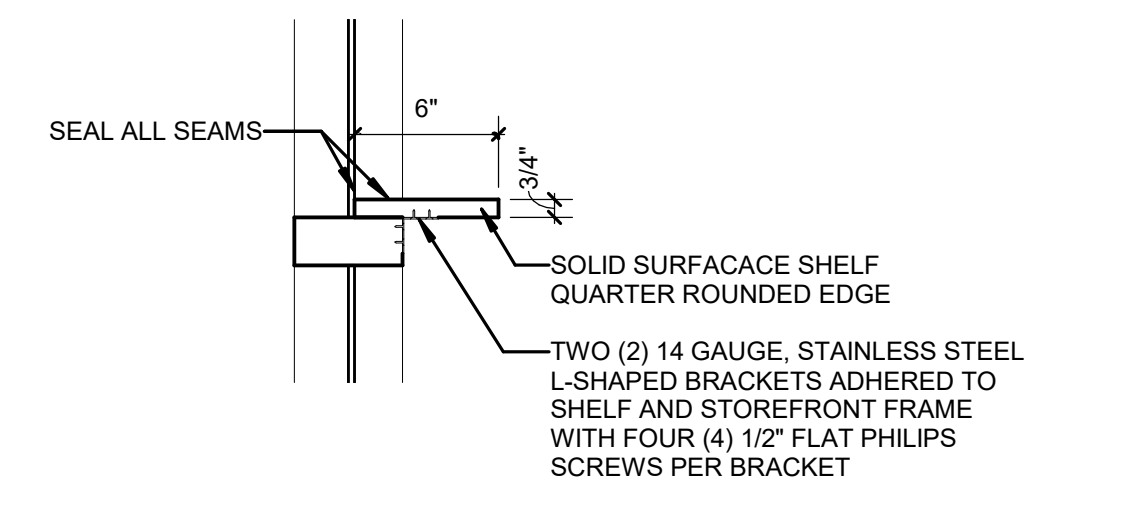

D5 SS-1 SHELF DETAIL 1 1/2" = 1'-0"

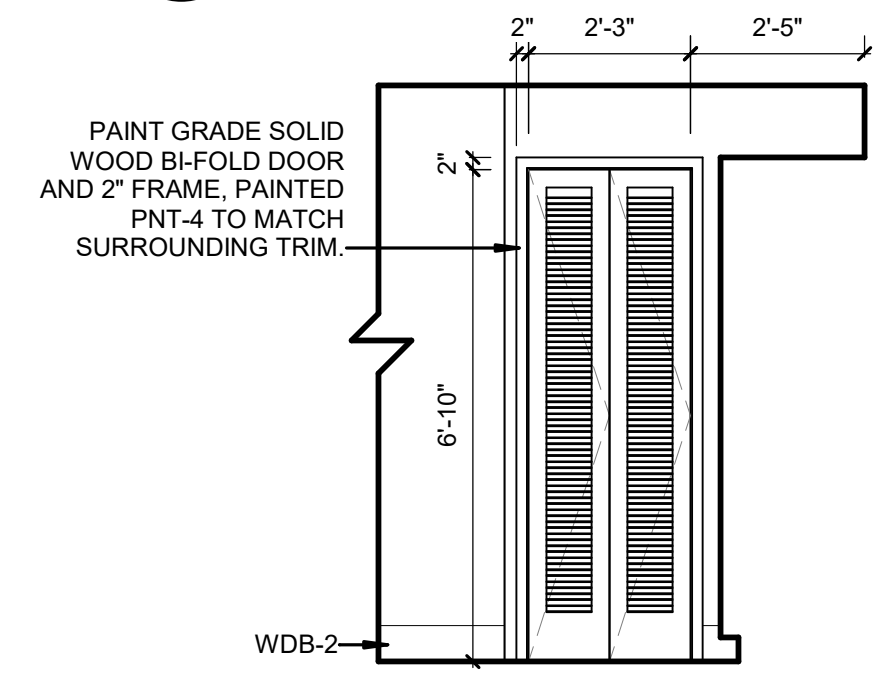

C5 ELEV-BREAK 152 W ALT 3/8" = 1'-0"

WALL TYPE LEGEND

- 6D 6" METAL STUD, 1 LAYER 5/8" GWB EACH SIDE. SOUND ATTENUATION BLANKET INSULATION. NOT RATED.

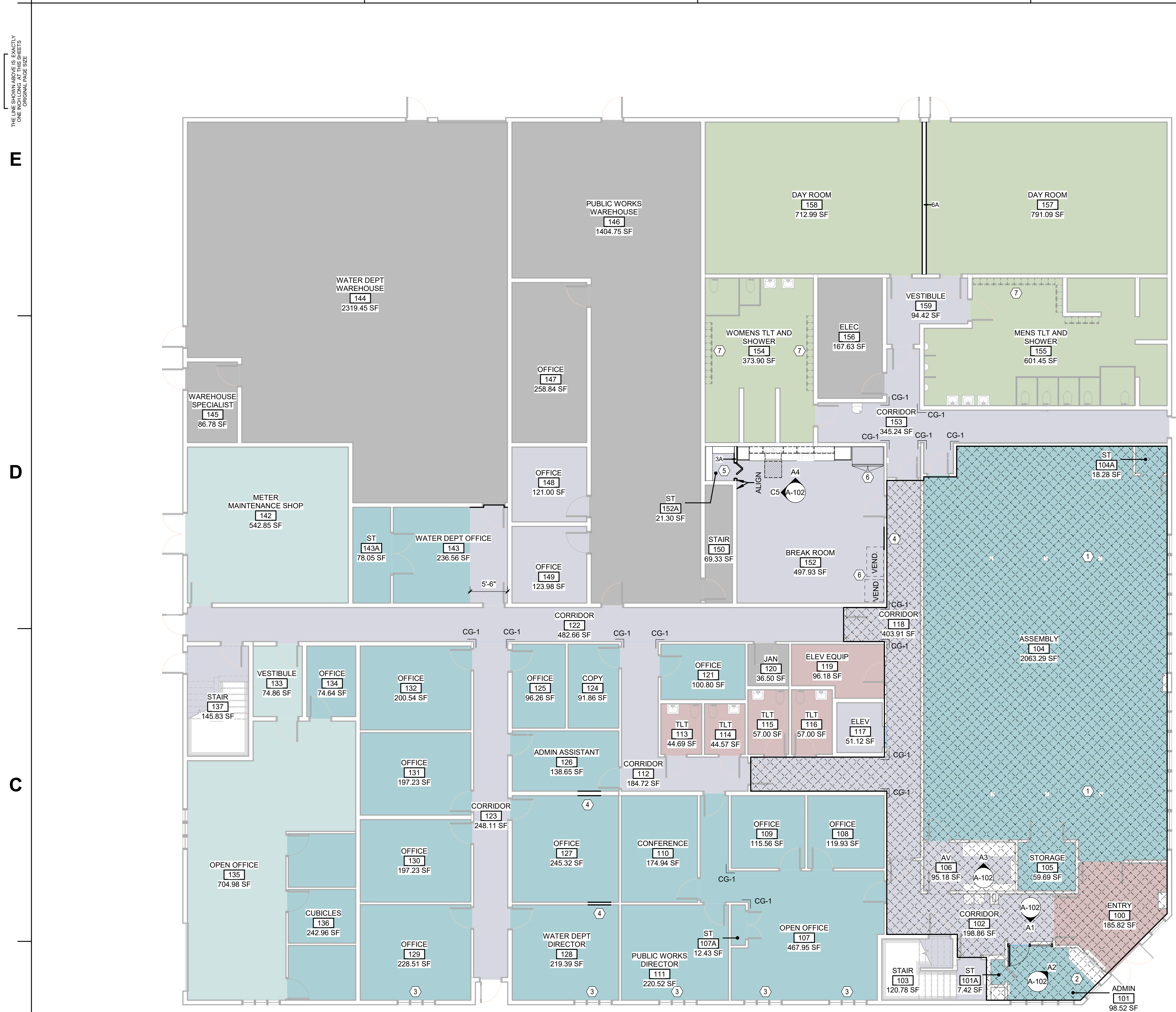

B1 ALTERNATE FLOOR PLAN 1/8" = 1'-0"

A1 ELEV - CORRIDOR 102 S ALT 3/8" = 1'-0"

A2 ELEV - ADMIN 101 NE ALT 3/8" = 1'-0"

A3 ELEV - AV 106 N ALT 3/8" = 1'-0"

A4 ELEV - BREAK 152 N ALT 3/8" = 1'-0"

2/20/2025 12:00:46 PM